

RESTRICTED

INSPECTORATE OF GENERAL STORES & CLOTHING
DHAKA CANTONMENT

SPECIFICATION NO. IGS & C/CLO/1070

DT. 21 OCT 2018

DRAWING NO. BD-GS-PD-1769

VOCAB SECTION: CF

CAT/PART NO. NIV

NOMENCLATURE: BERETS SIZE - 7 & 8

(In supersession of specification no IGS&C/Clo/941 dt 17 Nov 2016)

1. Basic Cloth

Name of Components	Material
a. Material %	100% Wool

Other Materials

Name of Components	Material
a. GSM-Wt/Sq Mtr (Basic Material)	540 ± 15 gm
c. Head Band (Rim)	a. Material : 100% Polyester b. Wt/Mtr : 7.0 ± 0.50 gm c. Colour : Black/Red (Red for BIR only)
c. Material of Lining	a. Hessian cloth no 2 underneath the crown. b. Poly Foam inside the entire Beret (between Hessian cloth & Polyester Black Taffeta Cloth). c. Polyester Black Taffeta Cloth (bottom layer).
d. Poly Foam	a. Material: 100% Polyester b. Wt/Sq Mtr : 60 ± 15 gm c. Type of Foam: Air Role Feather Touch d. Poly Foam quilted with Polyester Black Taffeta Cloth.
e. Tying Ribbon	Polyester/PP (Poly Propylene)
f. Material of Flap	Kari board/Paper board covered with Polyester Black Taffeta Cloth.
g. Eyelet	Brass
n. Shrinkage%	2% (Max)

1 of 5

RESTRICTED



3. Parameters of Components

Name of Components	Chemical/Physical Properties	Visual Properties
a. <u>Colour</u>		
(i) BD Green	-	Rain Forest (Pantone Colour Code 19-5232 TCX)
(ii) Dark Blue	-	Night Sky (Pantone Colour Code 19-3924 TCX)
(iii) Deep Maroon	-	Sun-Dried Tomato (Pantone Colour Code 19-1531 TCX)
(iv) Royal Blue	-	Limoges (Pantone Colour Code 19-4044 TCX)
(v) Azure Blue	-	Deep Water (Pantone Colour Code 18-4032 TCX)
(vi) Dull Chery	-	Bitter Chocolate (Pantone Colour Code 19-1317 TCX)
(vii) Black	-	Black Beauty (Pantone Colour Code 19-3911 TCX)
(viii) Scarlet	-	Haute Red (Pantone Colour Code 19-1758 TCX)
b. <u>Dye Fastness to Washing Test No-2.</u> (i) Reagent -0.2% free alkali soap (ii) Temperature -60°C (iii) Time -1 ¹ / ₂ hours	Grey scale rating 5	-
c. Dye-fastness to Sunlight Test (48 hours)	Grey scale rating 5	-

4. Measurement of Beret.

Ser	Description	Size-7	Size-8
a	Circumference of Beret (Inner side) (A)	56.0 cm	59.50 cm
b	Dia of Crown (B)	28.0 cm	28.0 cm
c	Bevel at Right	8.0 cm	8.0 cm
d	Bevel at Left	7.0 cm	7.0 cm
e	Bevel at Back	6.50 cm	6.50 cm
f	Bevel at Front	6.50 cm	6.50 cm
g	Full width of Ribbon (Head band)	2.54 cm	2.54 cm
h	Width of Head Band (Rim)	1.90 cm	1.90 cm
j	No of Eyelets	2 Nos	2 Nos
k	Distance between two Eyelets	2.50 cm	2.50 cm
l	Width of Tying Ribbon	0.70 cm	0.70 cm
m	Size of Flap	6.50 x 4.50 x 3.70 cm	6.50 x 4.50 x 3.70 cm
n	Weight	105 +5 gm	105 +5 gm

2 of 5

RESTRICTED



✓

RESTRICTED,

Packing Material

Packing	Material	Properties
Individual Packing	Polyethylene	Transparent and Self-adhesive.
Box Carton	Good quality corrugated paper carton	7 Ply. Securing with two Poly band strap (width wise).

Packaging After Inspection and Stamping, each Beret to be packed in a polythene bag containing one naphthalene ball of 3/4" x 5/8" size. Such 10 Nos Berets will be tied with twine ball to make a bundle. Such 20 bundles (20 x 10 = 200 Nos) will be packed in a 7 Ply corrugated paper carton of proper size with securing two poly band strap (width wise).

Drop Test. Carton used for packing should be of high quality. The carton should not fail in drop test with required no of products in it. Drop test to be done from two meters height thrice in any direction.

6 Marking

Item	Marking		Size & Material	Remarks
<p><u>Beret Label:</u> A label to be stitched with inner Lining of Crown mentioned the</p> <div style="border: 1px solid black; padding: 5px; width: fit-content;"> <p>Bangladesh Army Name of Store Size Name of Supplier Contract no & Dt Month & Yr of Mfc</p> </div>	<p><u>For Central Purchase</u> Bangladesh Army Name of Store Size Name of Supplier Contract no & Dt Month & Yr Mfc</p>	<p><u>For Local Purchase</u> Bangladesh Army LP by COD Name of Store Size Name of Supplier Purchase Order No & Dt Month & Yr of Mfc</p>	<p>1. Label material- Polyester 2. Clearly visible size</p>	<p>Details of label should be printed by black ink</p>
Carton (Front side)	<p><u>For Central Purchase</u> Bangladesh Army Name of Store Size: Name of Supplier & Address: Cont No & Dt: Month & Yr of Mfc: Qty:</p>	<p><u>For Local Purchase</u> Bangladesh Army Name of Store Size: Name of Supplier & Address: Purchase Order No & Dt: Month & Yr of Mfc: Qty:</p>	Clearly visible	
Carton (Rear side)	<p>Name of Consignee: Address:</p>		Clearly visible	



7. Samples

Ser	Types of samples	Complete Sample	Remarks
1.	Tender	03 (Three) nos samples for each Size should be submitted as Tender sample.	Will be provided by the supplier at free of cost.
2.	Advance	03 (Three) nos samples for each colour of each size with packing material should be submitted as Advance sample.	
3.	Advice (If required)	03 (Three) nos samples for each colour of each Size with packing material should be submitted as Advance sample.	
4.	Bulk Representative (BR)	06 (Six) nos from each Colour for each challan will be collected as BR sample.	

8. Condition of Test. If any sample (Tender, Advance & BR) can not be tested by IGS&C then those should be tested at any internationally reputed laboratory in Bangladesh. The supplier should pay test cost as per DP-35 sub para-12(A&B).

9. Quality Control Certificate/Quality Inspection by Supplier.

a. Supplier has to provide a certificate (along with all challan) that they have carried out a comprehensive quality inspection at their end and they are fully confirmed and satisfied about the following:

1. Products are produced/manufactured as per specification.
2. Products are tested/inspected as per the specified testing mentioned in this specification and found correct.

b. Supplier must also provide fabric (basic cloth) test report. Fabric (basic cloth) to be tested from any internationally reputed laboratory.

10. Warranty/Guarantee. The warranty/guarantee period of the store will be 16 (Sixteen) months from the issue of Inspection Note by IGS&C. In this regard the Manufacturer/Supplier should provide a warranty/guarantee certificate regarding durability of the supplied stores. If the supplied stores found defective within 16 (Sixteen) months during storage or 03 (Three) months of intended practical use (Under normal use with standard maintenance) then the defective stores should be replaced by the manufacturer/supplier at their own cost within 30 (Thirty) days at COD. Dhaka Cantt as the case arises.

11. Advance Sample & Bulk Representative (BR) Sample. Sample should be submitted at free of cost for Lab & Visual test (As per sub para-12 d(ii) & 12c(i & ii) of DP-35).



Notes:

- a. The Beret should be knitted in one piece.
- b. Shade will be as per requirement and approved sample held in IGS&C.
- c. There should be an agreement between supplier and manufacturer where supplier will produce product from a specific factory (Maximum three factories can be nominated by the supplier to avoid unforeseen situation for which the primarily selected manufacturer or factory owner by the supplier might not be able to run the factory/machineries, i.e natural disaster,unavoidable mechanical failure of machines etc) and submit with tender. Later on the supplier will produce 100% product from the same factory. The supplier must submit one copy of this agreement initially to DGDP. The supplier will submit the final agreement on stamp between supplier and manufacturer to DGDP while contract is being processed with DGDP.

Recommended by

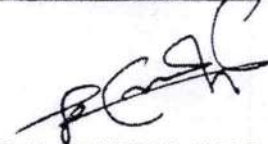

S M SHAMSUL SALEKIN
Col
Chief Inspector

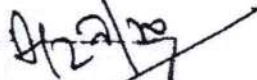

Approved
ITD Dte

APPROVED BY

DITD, ITD Dte

5 of 5
RESTRICTED

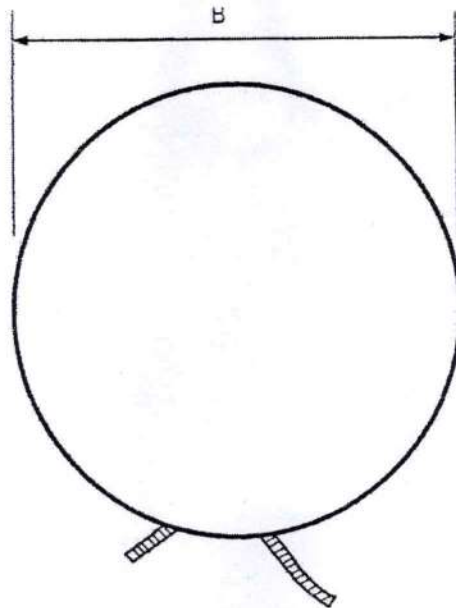



FRONT VIEW

HEAD BAND - POLYESTER BLACK/RED
(RED FOR BIR ONLY)

POLYESTER TAFFETA CLOTH

INNER POLY FOAM QUILTED WITH TAFFETA CLOTH

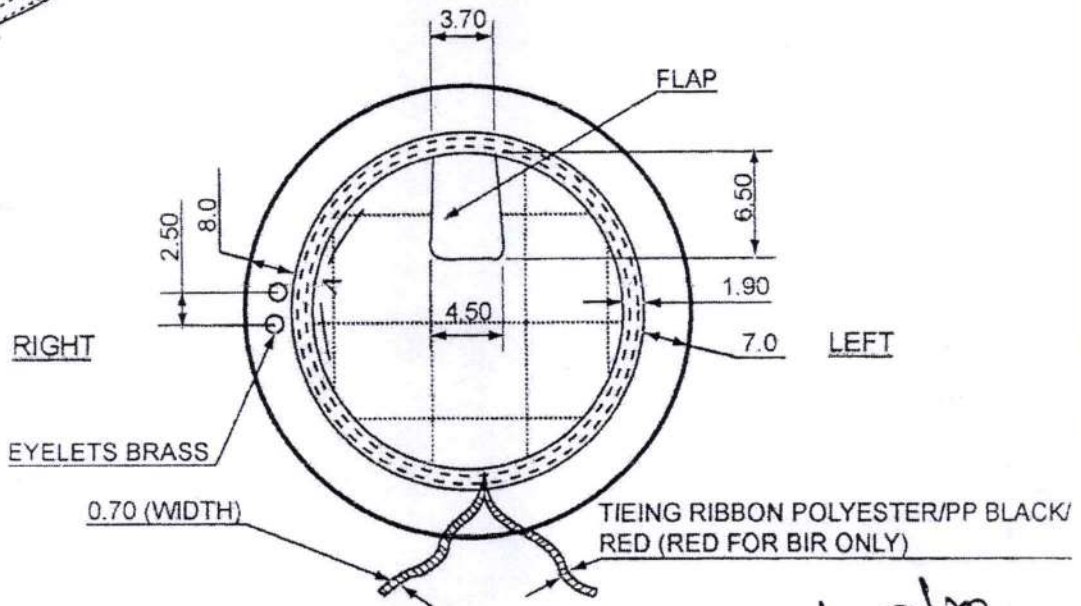
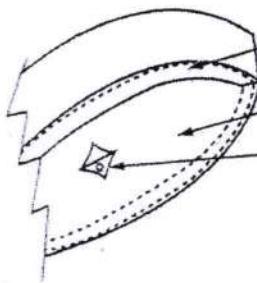

BACK VIEW

Approved
ITD Dte

MEASUREMENT

S/NO	DESCRIPTION	SIZE-7	SIZE-8
A	CIRCUMFERENCE	56.0	59.50
B	DIA	28.0	28.0

ALL MEASUREMENT SHOWN IN CM

DRAWN	Nadina	RECOMMENDED	
COMPARED		APPROVED	
CHECKED		DATE	
PASSED		NOT TO SCALE	

TITLE: **BERETS SIZE - 7 & 8**

IGS&C
DHAKA CANTT
DRG NO BD GS
PD- 1769



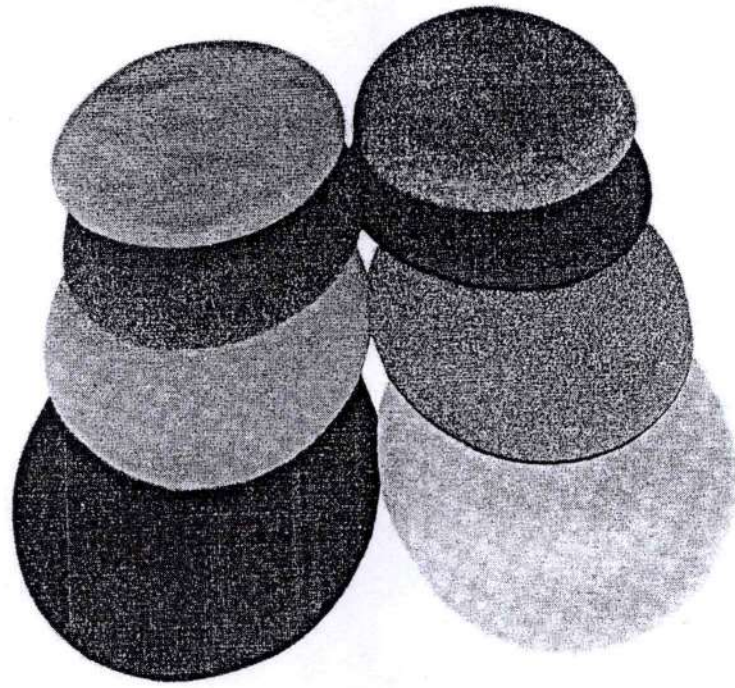

BERETS

(মাপনী মোতাবেক নয়, শুধুমাত্র রং ও ডিজাইনের জন্য)

