

(02)

RESTRICTED

**INSPECTORATE OF GENERAL STORES & CLOTHING**  
**DHAKA CANTONMENT**

SPECIFICATION NO. IGS&C/CLO/1229 DT: 27/ Aug 2023 DRAWING NO. BD-GS-PD-1945

VOCAB SECTION: CC

CAT/PART NO. NIV

NOMENCLATURE: T-SHIRT/SPORTS VEST (WITH COLLAR) FOR JCO

1. **Basic Materials**

Name of Component	Material
Basic Fabric	100% Polyester ( Pin hole mesh)

2. **Trims**

Ser	Name of Component	Material
a.	Collar	100% Polyester ( Knitted-Rib)
b.	Collar binding cloth (inside)	100% Polyester ( Knitted)
c.	Design of collar	Must be as per approved sample held in IGS&C.

3. a. **Shade**

Ser	Name of Component	Name of Color	Pantone Color
a.	Color of body cloth & collar	Lucent white	Pantone code 11-0700 TCX
b.	Monogram base	Fern green	Pantone code 17-6153 TCX
c.	Monogram shapla	Golden kiwi	Pantone code 13-0644 TCX

4. **Sewing Threads** (Sewing threads color must match with the color of basic fabric)

Ser	Name of Components	Material and Type
a.	Collar, bottom seam allowance, sleeve seam allowance & shoulder	100% Polyester and 2 rows flat lock stitch
b.	Armpit, bottom of sleeve & two sides of body	100% Polyester and Over lock stitch

5. **Classification of Dyestuff.** Disperse (Germany, Switzerland or equivalent International quality)

27/8



1  
RESTRICTED



6. Test Parameter

Ser	Name of Material	Chemical/Physical Properties	Visual Properties
a.	Basic fabric	Silicon Enzyme washed & hydraulic finished	a. Must be free from naps, slubs, knitting & dyeing fault, crease and wrinkle. b. Must be soft & smooth.
b.	Type of weave	Knitted (Pin hole mesh)	-
c.	Weight per square Meter (GSM)(ISO 3801)	150±5 gm	-
d.	Denier of Yarn	75.0 <sup>d</sup>	-
e.	No of Wales/2.54 cm	44/45 nos	-
f.	No of Course/2.54 cm	54/55 nos	-
g.	<u>Shrinkage (By machine)</u> (ISO 6330: 2012 4N)		
	(1). Length	2.0% (Max)	-
	(2). Chest	2.0% (Max)	-

7. Test Parameter.

Ser	Name of Tests	Test Method	Rating Scale
a.	<u>Washing Test No-2</u> (1) Soap (Alkali free) - 0.2% (2) Temperature - 60°C (3) Time - 1½ (One & half) hours	ISO 105 C02	Grey scale rating 4/5
b.	<u>Rubbing Test</u> Rubbing with Ordinary soap in cold & hot water at 60°C Temperature	Inhouse method	Grey scale rating 4/5
c.	10 times wash (Soap washing/ Detergent powder)	ISO 6330: 2000 5A	Grey scale rating 4/5
d.	Sunlight test (72 hours)	ISO 105 B02	Grey scale rating 4/5
e.	Resistance to Pilling (10,000 cycles)	ISO 12945-1 (2000 E) & ISO 12945-2 (2000 E)	Rating Grade 4
f.	Resistance to Abrasion (10,000 cycles)	ISO 12947-4	Rating Grade 4

2/3/18



(5)

RESTRICTED

8 a. Dimensional Measurements

Ser	Description	Size-S	Size-M	Size-L	Size-XL	Size-XXL	Size-XXXL
(1)	Full length (A)	69±1cm	71±1cm	73±1cm	75±1cm	77±1cm	79±1cm
(2)	Chest (Round) (B)	102±1Cm	105±1cm	108±1cm	111±1cm	114±1cm	117±1cm
(3)	Yoke (C)	44.0 cm	46.0 cm	48.0 cm	50.0 cm	52.0 cm	54.0 cm
(4)	Upper Sleeve length (D)	22.0 Cm	22.0 cm	23.0 cm	24.0 cm	25.0 cm	26.0 cm
(5)	Lower Sleeve length (E)	11.0 cm	12.0 cm	13.0 cm	14.0 cm	15.0 cm	16.0 cm
(6)	Width of sleeve open portion (F)	17.0 cm	18.0 cm	19.0 cm	20.0 cm	21.0 cm	22.0 cm
(7)	Width of sleeve seam	2.5 cm	2.5 cm	2.5 cm	2.5 cm	2.5 cm	2.5 cm
(8)	Length of Round bottom (G)	102.0 cm	105.0 cm	108.0 cm	111.0 cm	114.0 cm	117.0 cm
(9)	Length of Collar (H)	42.0 cm	42.0 cm	43.0 cm	44.0 cm	45.0 cm	46.0 cm
(10)	Width of Collar (J)	8.5 cm	8.5 cm	8.5 cm	8.5 cm	8.5 cm	8.5 cm
(11)	Width of round bottom seam (K)	2.5 cm	2.5 cm	2.5 cm	2.5 cm	2.5 cm	2.5 cm
(12)	Depth of Arm hole (L)	26.0 cm	27.0 cm	28.0 cm	29.0 cm	30.0 cm	31.0 cm
(13)	Size of collar strengthened cloth (Inside) (Length × Width)	43×1.0 cm	44×1.0 cm	45×1.0 cm	46×1.0 cm	47×1.0 cm	48×1.0 cm
(14)	Size of strengthened piece inside of yoke (Length × Width)	22×8.5 cm	22×8.5 cm	22×8.5 cm	22×8.5 cm	22×8.5 cm	22×8.5 cm
(15)	Size of Button plate (Length×Width) (M×N)	15×3 cm	15×3 cm	15×3 cm	15×3 cm	15×3 cm	15×3 cm

2/31/18



RESTRICTED

Ser	Description	Size-S	Size-M	Size-L	Size-XL	Size-XXL	Si. XXX
(16)	No of Button & Button color to be matched with basic cloth All button to be engraved with the words "Bangladesh Army"	03 Nos White	03 Nos White	03 Nos White	03 Nos White	03 Nos White	03 Nos White
(17)	Distance between Two Button	Equal distance	Equal distance	Equal distance	Equal distance	Equal distance	Equal distance
(18)	Size of Button (Dia×Thicknes s)	1.20×0.20 Cm	1.20×0.20 cm	1.20×0.20 Cm	1.20×0.20 Cm	1.20×0.20 Cm	1.20×0.20 Cm
(19)	Total weight of each Vest	175±5 Gm	180±5 gm	185±5 gm	190±5 gm	200±5 gm	205±5 gm

b. Measurement of Bangladesh Army Monogram.

Ser	Name of Component	Size-S	Size-M	Size-L	Size-XL	Size-XXL	Size-XXXL
(1)	Distance of cross point of two sword (Monogram) from top of shoulder (P)	23.0 cm	23.0 cm	23.0 cm	23.0 cm	23.0 cm	23.0 cm
(2)	Distance of cross point of two sword (Monogram) from Button plate (Q)	9.0 cm	9.0 cm	9.0 cm	9.0 cm	9.0 cm	9.0 cm
(3)	Dia of Monogram (R)	4.30 cm	4.30 cm	4.30 cm	4.30 cm	4.30 cm	4.30 cm
(4)	No of Monogram (left side)	01 no	01 no	01 no	01 no	01 no	01 no
(5)	Height of Shapla	1.0 cm	1.0 cm	1.0 cm	1.0 cm	1.0 cm	1.0 cm
(6)	Width of Shapla	1.50 cm	1.50 cm	1.50 cm	1.50 cm	1.50 cm	1.50 cm
(7)	Width of Golden Border & Sword	0.20 cm	0.20 cm	0.20 cm	0.20 cm	0.20 cm	0.20 cm

9. Packing Details.

Ser	Packing	Material	Properties
a.	Individual packing	a. Paper board b. Poly ethylene	a. 360 GSM b. Transparent and Self-adhesive bag.
b.	Box carton	Corrugated paper carton	9 ply Securing with two Poly Propiline band strap including metal clip (width wise).



(U)

RESTRICTED

10. **Packing.** Each T-Shirt/Sports Vest (with Collar) should be folded with paper board and put in a Self- adhesive polyethylene bag. Such as 100 nos vest should be packed in a box carton (9 Ply Carton) with large size 04 (Four) naphthalene balls. After packing the carton to be wrapped with good quality scotch tape, then it will be tied with 04 (Four) poly band tape (length wise-2 bindings & width wise-2 bindings) fixed with metallic tips.
11. **Carton Drop Test.** Carton used for packing should be of high quality. The carton should not crack in drop test while it is filled up with the concerned products in actual quantity and dropped for three times from two meter height in any direction.
12. **Marking on Item.** (Label should include methods for washing, drying, ironing along with mentioned below).

Item	Marking	Material & Size	Remark
<p><b><u>Main label (Front Side)</u></b> (For central purchase)</p> <p>Should be attached by stitching at right (Inner) side 10 cm above from round bottom</p>	<ul style="list-style-type: none"> <li>• BD ARMY</li> <li>• Product Name &amp; Size</li> <li>• Name of Supplier</li> <li>• Cont. No &amp; Dt</li> <li>• Manufacturing Month &amp; Year</li> <li>• Warranty</li> <li>• Shelf-life</li> </ul>	<p>a. Cloth of Label: Polyester</p> <p>b. Coating: Poly Urethene (PU)</p> <p>c. Required Size</p>	<p>Indelible black color letters on white background</p>
<p><b><u>Main label (Inner Side)</u></b></p> <p>Care label &amp; Instruction</p>	<ul style="list-style-type: none"> <li>• Washing and Cleaning instructions as required: Washing, Drying, Ironing &amp; etc.</li> </ul>	<p>a. Cloth of Label: Polyester</p> <p>b. Coating: Poly Urethene (PU)</p> <p>c. Required Size</p>	<p>Indelible black color letters on white background</p>
<p><b><u>Main label &amp; Care label</u></b> (For local purchase)</p> <p>Should be attached by stitching at right (Inner) side 10 cm above from round bottom</p>	<ul style="list-style-type: none"> <li>• BD ARMY</li> <li>• LP-COD</li> <li>• Product Name &amp; Size</li> <li>• Name of Supplier</li> <li>• LP Cont. No &amp; Dt</li> <li>• Manufacturing Month &amp; Year</li> </ul>	<p>a. Cloth of Label: Polyester</p> <p>b. Coating: Poly Urethene (PU)</p> <p>c. Required Size</p>	<p>Indelible black color letters on white background</p>
<p><b><u>Main label (Inner Side)</u></b></p> <p>Care label &amp; Instruction</p>	<ul style="list-style-type: none"> <li>• Washing and Cleaning instructions as required: Washing, Drying, Ironing &amp; etc.</li> </ul>	<p>a. Cloth of Label: Polyester</p> <p>b. Coating: Poly Urethene (PU)</p> <p>c. Required Size</p>	

Note: Approval for the labels to be taken from IGS&C before going for bulk Production.



RESTRICTED

13. Note: Approval for the labels to be taken from IGS&C before going for Production.

14. Marking (Hang Tag).

Item	Marking	Size	Remark
Hang Tag (Should be attached with size sticker at Collar)	a. One side: Army Logo & BD Army b. Other side: Size & Not For Sale	8x4 cm	a. One side: BD Army & Logo should be printed on BD green background by golden letter.  b. Other side should be printed on white background by black letter.

15. Note: Approval for the hang tag to be taken from IGS&C before going for bulk Production.

16. Marking on Master Carton.

One Side		On the Other Side
<u>For Central Purchase</u> (1) Bangladesh Army (2) Name of Store & size (3) Name of supplier & address (4) Cont no & dt (5) Month & year of production (6) Quantity of the item packed (7) I/Note no & Date (8) Warranty (9) Shelf-life	<u>For local Purchase</u> (1) Bangladesh Army (2) Name of Store & size (3) Name of supplier & address (4) Purchase no & dt (5) Month & year of production (6) Quantity of the item packed (7) Warranty (8) Shelf-life	Consignee's Name & Address

17. Sample.

Type of Sample	Quantity	Remarks
Tender Sample (Complete)	06 (Six) nos samples of highest indented size mentioned in the indent/tender to be submitted as tender sample.	Free of cost
Advance Sample	03 (Three) nos samples of each size with packing material to be submitted as Advance sample.	
Advice Sample (if require)	03 (Three) nos samples of each size with packing material to be submitted as Advice sample.	
BR Sample	03 (Three) nos samples of each size will be collected against Each Challan quantity of 01 (One) thousands for Lab tests & visual tests.	



2/3/18

RESTRICTED

18. **Condition of Sample Test.** Tender, Advance & Bulk Representative (BR) sample of T-Shirt/Sports Vest (with Collar) will be tested in any recognized laboratory available in Bangladesh if the testing facility is not available at IGS&C laboratory. The necessary cost of laboratory tests will be paid by supplier as per sub para 12 a & b of DP-35.

19. **Test Report and Quality Control Certificate by Supplier.** Supplier has to provide fabric/product test report (for tests mentioned at ser 6 & 7) from any reputed testing organization (e.g. Intertek, SGS, Bureau veritas. etc) along with advance sample and subsequent each challan. Supplier should also provide Quality Control (QC) certificate that they have carried out a comprehensive quality inspection at their end and they are fully confirmed and satisfied according to the points as mentioned below along with each challan:

- a. Products are produced/manufactured as per specification.
- b. Products are tested/inspected as per the specified tests mentioned in this specification and found correct.

20. **Warranty/Guarantee.** The warranty/guarantee period of the store will be 12 (Twelve) months from the issue of Inspection Note by IGS&C. In this regard the manufacturer/supplier should provide a warranty/guarantee certificate regarding durability of the supplied stores. If supplied stores found defective within 12 (Twelve) months during storage or practical use (Under normal use with standard maintenance), then defective Item to be replaced completely or partially (as necessary) by the manufacturer/supplier at their own cost within 30 (Thirty) days as the case arises.

21. **Stage Inspection.** Stage Inspection can be carried out during production at the discretion of IGS&C if the product is manufactured locally.

22. **Advance & Bulk Representative Sample.** Advance & Bulk Representative (BR) Sample should be submitted by supplier at free of cost for lab & visual tests (As per sub para 12 d (ii) & 12 c (i & ii) of DP-35).

23. **Note.**

- a. In case of local sourcing there should be an agreement between supplier and manufacturer where supplier will produce product from a specific factory (Maximum three factories can be nominated by the supplier to avoid unforeseen situation for which the primarily selected manufacturer or factory owner by the supplier might not be able to run the factory/machineries; i.e natural disaster, unavoidable mechanical failure of machines etc) and submit with Tender. Later the supplier will produce 100% product from the same factory. The supplier must submit one copy of this agreement initially at DGDP. The supplier will submit the final agreement on stamp between supplier and manufacturer to DGDP while contract is being processed with DGDP.

3118



RESTRICTED

- b. Basic fabric of T-Shirt/Sports Vest (with Collar) must have Hydraulic finish.
- c. Basic fabric of T-Shirt/Sports Vest (with Collar) must be washed by Sil Enzyme after knitted.
- d. Basic fabric of T-Shirt/Sports Vest (with Collar) must be smooth & soft (As per sample held in IGS&C).
- e. Each T-Shirt/Sports Vest (with Collar) must be free from naps, slabs, knitting & dyeing fault.
- f. Cloth of T-Shirt/Sports Vest (with Collar) must be free from crease & wrinkle.
- g. Collar, round bottom, sleeve seam allowance & yoke must contain 2 rows flat lock stitch with matching thread.
- h. Armpit, bottom of sleeve and two sides of body must be secured with over lock stitch with matching thread.
- j. Rear side of body must be as per approved drawing.
- k. Bangladesh Army Monogram should be embroidered by ochre polyester/nylon threads (Good quality).
- l. Make Shape design and other details should be as per specification, drawing and approved sample basis (Sample held in IGS&C, Dhaka Cantt)

Recommend by

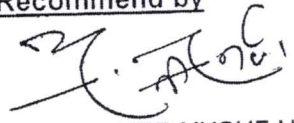

KHANDAKER YUSUF HASAN  
Col  
Chief Inspector

A3 05/12/23  
Approved  
ITD Dte

Approved by



Director, ITD Dte

8

RESTRICTED

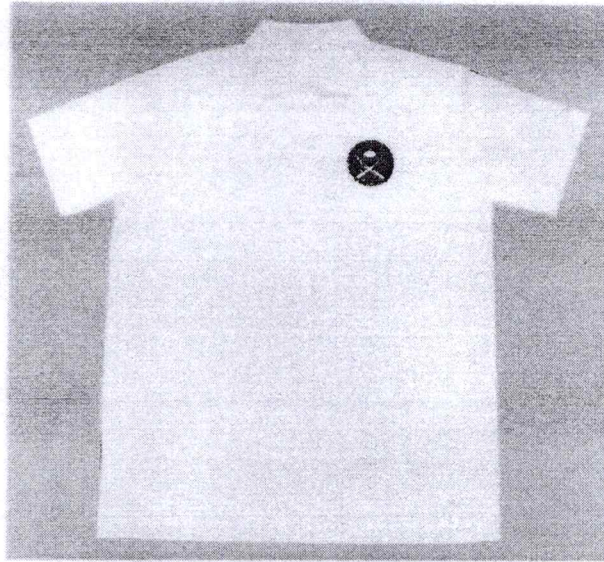

**FRONT VIEW**

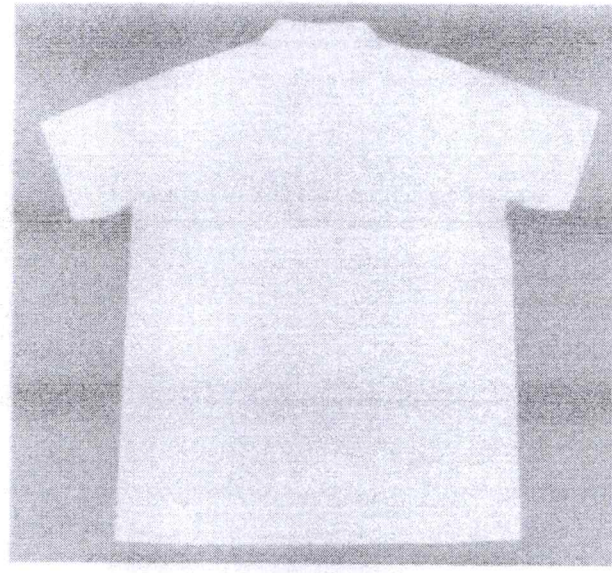

**BACK VIEW**

*Handwritten signature*

**T-SHIRT/SPORTS VEST  
(WITH COLLAR) FOR JCO**

A3 0519123  
Approved  
ITD Dte

(মাপনী মোতাবেক নয়, শুধুমাত্র ডিজাইনের জন্য)



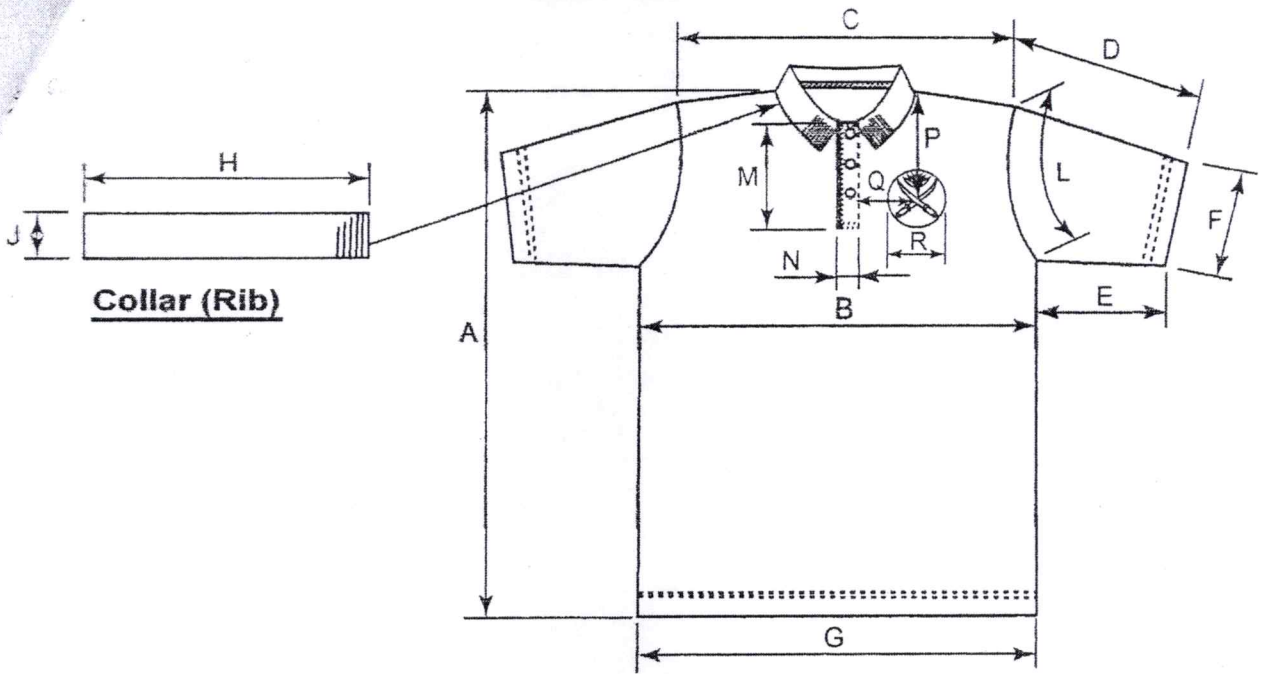

**Collar (Rib)**

**FRONT VIEW**

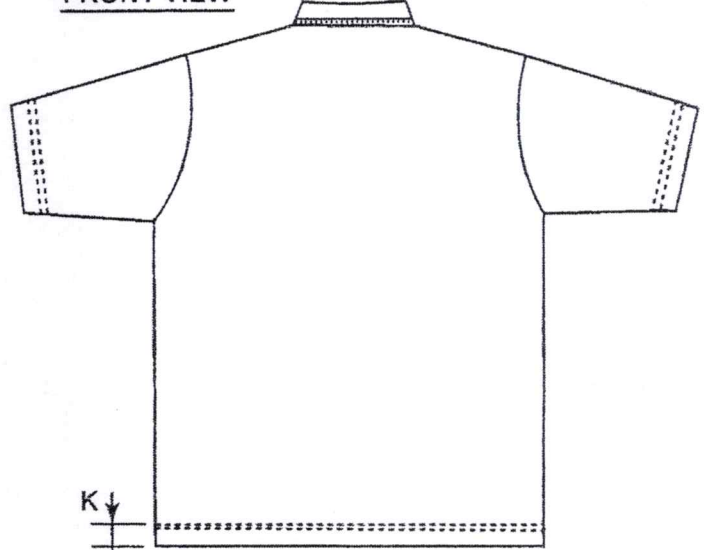

**BACK VIEW**



**FRONT**



**REAR**

**HANG TAG**

ALL MEASUREMENTS SHOWN IN CM

DIM	SIZE-S	SIZE-M	SIZE-L	SIZE-XL	SIZE-XXL	SIZE-XXXL
A	69.0±1	71.0±1	73.0±1	75.0±1	77.0±1	79.0±1
B	102.0±1	105.0±1	108.0±1	111.0±1	114.0±1	117.0±1
C	44.0	46.0	48.0	50.0	52.0	54.0
D	22.0	22.0	23.0	24.0	25.0	26.0
E	11.0	12.0	13.0	14.0	15.0	16.0
F	17.0	18.0	19.0	20.0	21.0	22.0
G	102.0	105.0	108.0	111.0	114.0	117.0
H	42.0	42.0	43.0	44.0	45.0	46.0
J	8.5	8.5	8.5	8.5	8.5	8.5
K	2.5	2.5	2.5	2.5	2.5	2.5
L	26.0	27.0	28.0	29.0	30.0	31.0
MxN	15.0x3.0	15.0x3.0	15.0x3.0	15.0x3.0	15.0x3.0	15.0x3.0
P	23.0	23.0	23.0	23.0	23.0	23.0
Q	9.0	9.0	9.0	9.0	9.0	9.0
R	4.30	4.30	4.30	4.30	4.30	4.30

A3 0519123  
Approved  
ITD Dto

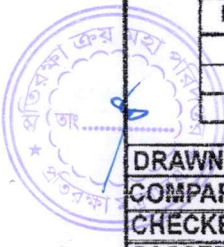

DRAWN	Nadira	RECOMMENDED	[Signature]
COMPARED	[Signature]	APPROVED	[Signature]
CHECKED	[Signature]	DATE	
PASSED	[Signature]	NOT TO SCALE	

**T-SHIRT/SPORTS VEST  
(WITH COLLAR) FOR JCO**

IGS&O  
DHAKA CANTT  
DRC NO-80 GS  
PD - 1945